

AGM-12-200

Valve-regulated lead-acid battery



GENERAL PURPOSE SERIES

Characteristics

Nominal voltage	12V (6 cells per unit)	
Nominal capacity at 20 hours rate/10.8V (25°C)	200Ah	
Capacity (25°C)	10 Hours rate/10.8V	180Ah
	5 Hours rate/10.8V	153.5Ah
Terminal type	T18	
Torque	12.3±2.5N.m	
Approx. internal resistance (25°C)	3.5mΩ	
Dimensions	Length	522±2mm (20.55inch)
	Width	238±2mm (9.37inch)
	Height	218±2mm (8.58inch)
	Total height (T14)	222±2mm (8.74inch)
Design Life (stand-by)	JIS at 25°C	10 years
	Eurobat at 20°C	10/12 years
Weight	54.0kg (131.20lbs)±3%	
Nominal operating temperature	25°C±3 (77±5°F)	
Operating temperature range	Discharge	-15°C~50°C (5°F~122°F)
	Charge	-10°C~50°C (14°F~122°F)
	Storage	-20°C~50°C (-4°F~122°F)
Float charging voltage at 25°C	13.5V~13.8V	
Cyclic charging voltage at 25°C	14.5V~15.0V	
Temperature compensation	Float charge	-18 mV/°C/Block
	Cycle charge	-30 mV/°C/Block
Max. charging current (A)	60A	
Max. discharge current for 5 seconds	1400A	
Self discharge rate (25°C)	≤3%/month	
Battery container ABS UL94-HB	V-0 optional	

Overview

General Purpose series batteries are de-signed with state-of-the-art AGM (absorbent glass mat) technology, high-performance plates and electrolyte. With excellent value and characteristics, this range is suitable for all general purpose applications.

Dimensions & Terminal Type (mm)

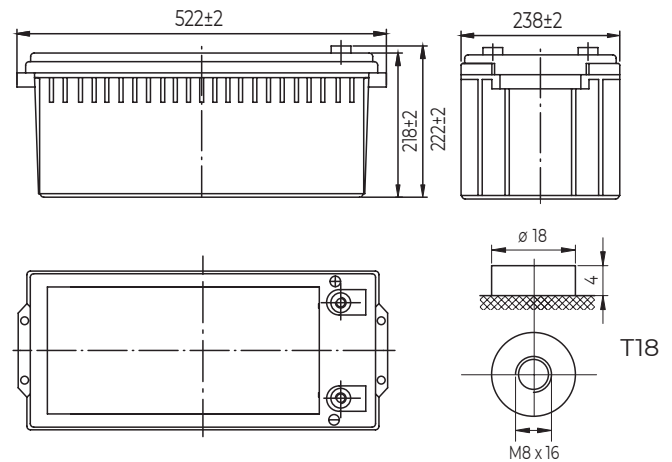

Construction

Component	Positive Plate	Negative plate	Container	Separator	Electrolyte	Safety valve	Terminal
Raw material	Lead dioxide	Lead	ABS (V-0 opt.)	AGM	Sulfuric Acid	Rubber	Copper

Constant current discharge characteristics at 25°C

(Ampere/battery)

F.V/Time	15min	30min	60min	2h	3h	4h	5h	6h	8h	10h	20h
9.60V	302	181	111	65.8	47.4	37.8	32.3	28.1	22.2	18.3	9.71
9.90V	295	177	110	65.4	47.1	37.6	32.1	27.9	22.1	18.3	9.69
10.2V	284	172	107	64.8	46.8	37.3	31.9	27.7	21.9	18.2	9.66
10.5V	275	168	103	63.8	46.4	37.1	31.7	27.5	21.8	18.1	9.61
10.8V	260	162	100	62.2	45.0	36.0	30.7	26.7	21.1	18.0	9.54

Constant power discharge characteristics at 25°C

(Watts/battery)

F.V/Time	15min	30min	60min	2h	3h	4h	5h	6h	8h	10h	20h
9.60V	3320	2030	1268	762	557	445	382	332	264	219	117
9.90V	3241	1989	1249	757	554	442	380	330	262	218	116
10.2V	3121	1928	1217	750	550	439	377	328	261	218	116
10.5V	3015	1882	1179	739	546	436	374	326	259	216	115
10.8V	2856	1813	1141	720	530	423	363	316	251	215	114

The above characteristics represent average values and can be obtained within three charge and discharge cycles. The batteries must be fully charged before testing. The data in this document is subject to change without notice and become contractual only after written confirmation. Please contact Conexpro for the latest available version.

Discharge characteristics (25°C)

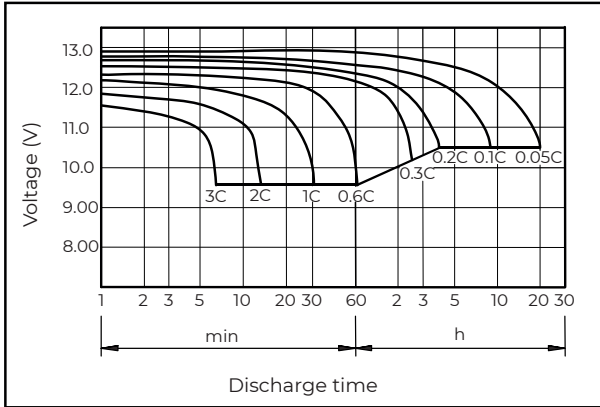

Charging characteristics (25°C)

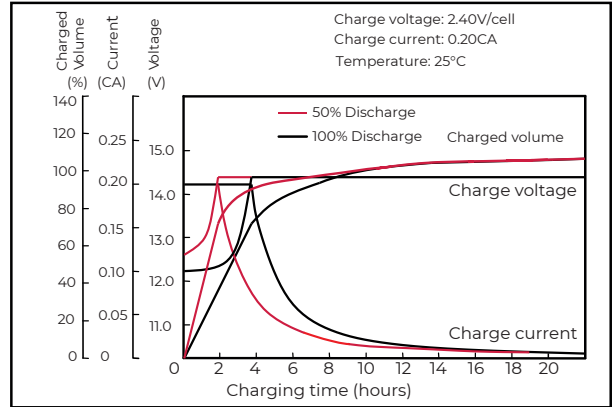

Temperature effects on capacity

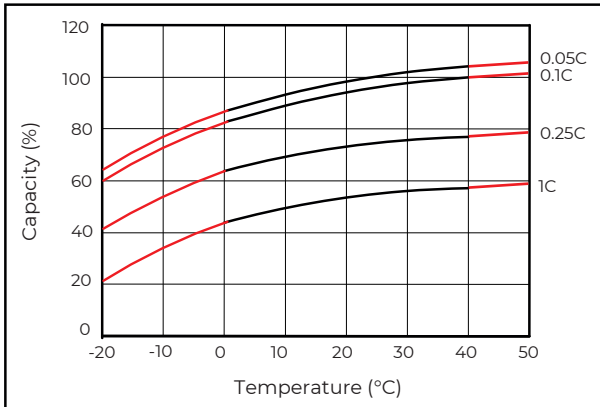

Self-discharge characteristics

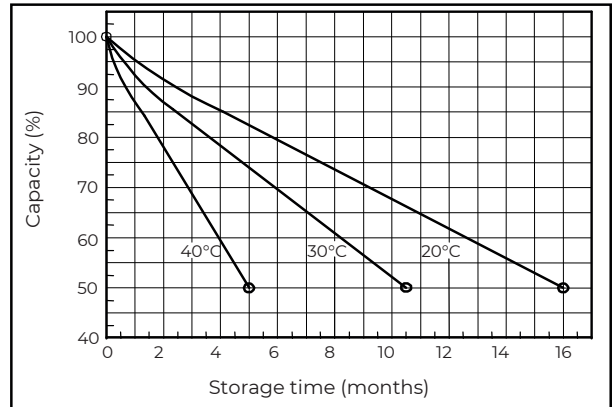

Floating life on temperature

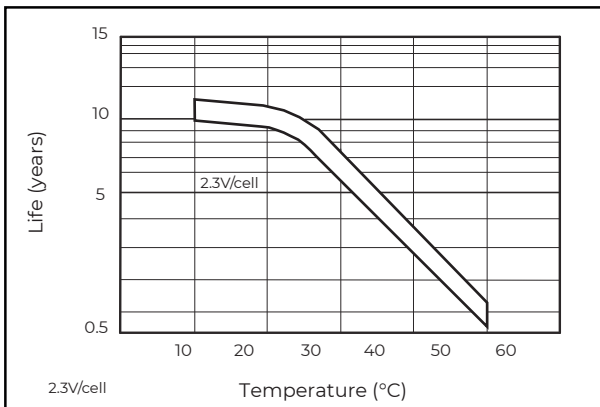

Cycle life on D.O.D (25°C)

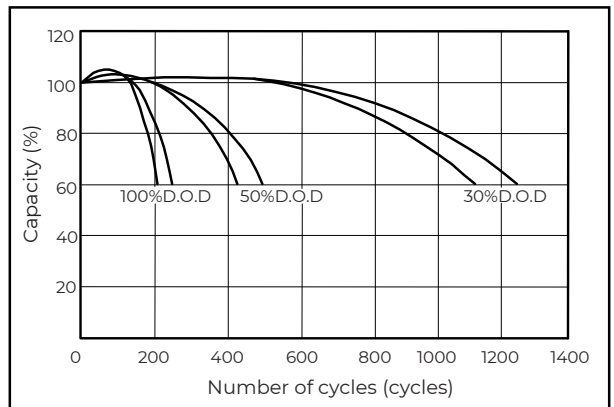

Relationship for OCV and capacity (25°C)

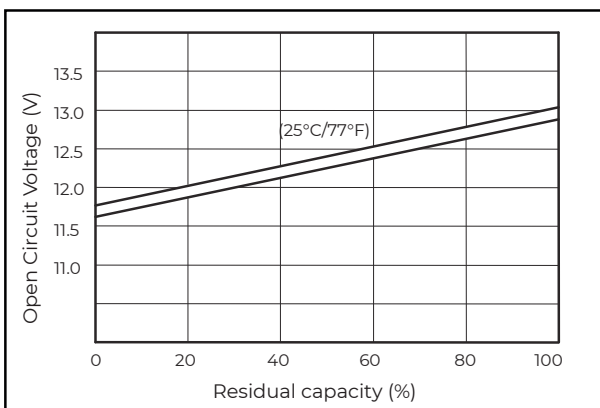

Charging voltage VS temperature

