

DEHUMIDIFIER

T-SERIES/F2-SERIES

MDT-10DKN3

MDF2-12DEN3
MDF2-16DEN3
MDF2-20DEN3



- Suitable for rooms of approx. **40m³, 60m³, 80m³, 100m³** (10, 12, 16, and 20 litres)
- Clear control panel with simple button adjustment
- **Frost and overflow protection**
- Indication of water level
- Foldable handle
- Cleaning-friendly **dust filter**
- Removable **water tank**
- **Silent operation**
- Eco-friendly refrigerant (CFC-free)
- **3-year warranty**

T-SERIES 10 Litres



3-year warranty



Removable dust filter



Humidity sensor

R134a

F2-SERIES 12, 16 + 20 Litres



3-year warranty



Removable dust filter



Humidity sensor



LED Display

R134a

Technical data

Model	Units	MDT-10DKN3	MDF2-12DEN3	MDF2-16DEN3	MDF2-20DEN3
Art.no.		7061072	7061272	7061672	7062072
EAN-no.		4048164610723	4048164612727	4048164616725	4048164620722
Colour		white	white/black	white/black	white/black
Electrical data					
Energy consumption	Watt	220	260	300	370
Voltage/frequency	V~/Hz	220-240/50	220-240/50	220-240/50	220-240/50
Performance data					
Air output	approx. m ³ /h	100	100	200	200
Dehumidification effect	approx. litres/24h	10	12	16	20
Water tank	Litres	1,5	3	3	3
Refrigerant		R134a	R134a	R134a	R134a
Noise level	from dB(A)	45	43	48	50

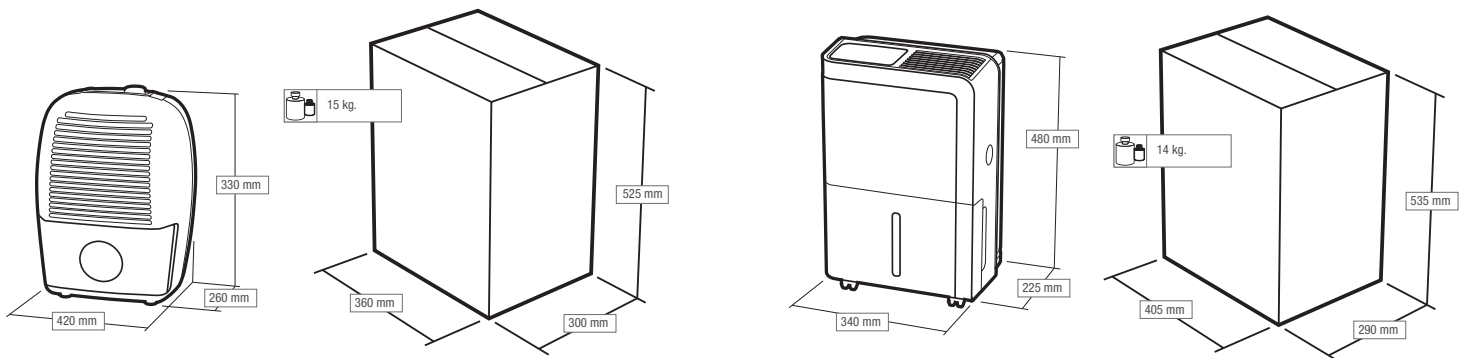

Measurements and weight					
Cable length incl. plug	approx. m	1,5	1,5	1,5	1,5
Product measurements	L x B x H ca. mm	330 x 260 x 420	325 x 225 x 480	340 x 225 x 480	340 x 225 x 480
Measurements, single carton	L x B x H ca. mm	360 x 300 x 525	405 x 290 x 535	405 x 290 x 535	405 x 290 x 535
Weight, single carton	approx. kg	15	13	14	14
Amount per parcel	pcs.	1	1	1	1
Amount per pallet	pcs.	12	12	12	12
Amount per container 40' HQ	pcs.	1280	1160	1160	1160

Performance may be affected by air humidity, roof inclination, and large glass facades/windows.

