

MOBILE AIR CONDITIONER

T-SERIES

MPT-09CRN1

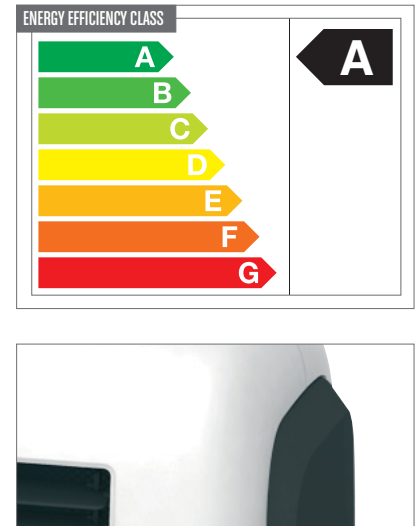
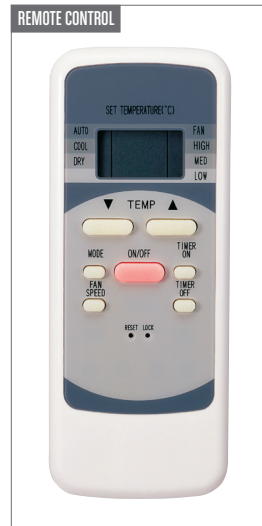

- Suitable for rooms of approx. **32m²**
- Convenient operation with different settings:
Cooling, dehumidification, ventilation
- 3 speeds
- Easy indoor climate regulation with **remote control**
- Low power consumption, **energy efficiency class A**
- Clear control panel with simple button adjustment
- Optimal air distribution by means of an electronic, adjustable air grille
- Eco-friendly refrigerant (CFC-free)
- 4L water tank
- **3-year warranty**

3
Garantie

3-year warranty



Dehumidification



Remote control

24h

Timer



LED Display

R410a

COOLIX

MIDEA EUROPE GmbH | Zülpicher Str. 5 | D-40549 Düsseldorf | Telefon: +49 (0) 211 50 86 49-0 | Telefax: +49 (0) 211 50 86 49-19 | www.mideaaircon.de

Technical data

Model	Units	MPT-09CRN1
Art.no.		8020992
EAN no.		4048164209927
Colour		white/grey
Electrical data		
Energy consumption, cooling	Watt	1010
Voltage/frequency	V~/Hz	220-240/50
Performance data		
Cooling effect	BTU/h	9.000
	W/h	2.640
Air output	approx. m ³ /h	380
Dehumidification effect	approx. litres/24h	40
Water tank	litres	4
Refrigerant		R410a
Energy efficiency class: cooling function		A
Noise level	from db(A)	49
Ideal room size*	approx. m ³	80
Ideal residential area* with a floor-to-ceiling height of approx. 2.51m	approx. m ²	32

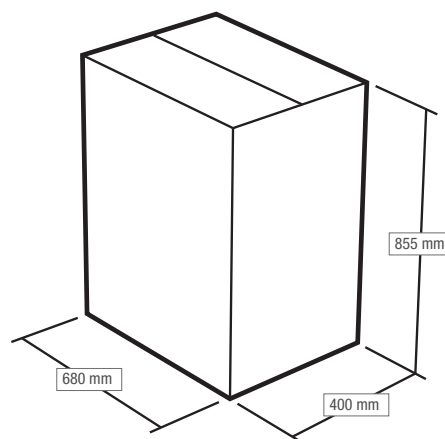
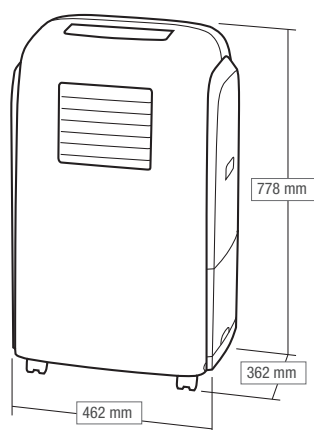

Measurements and weight

Cable length incl. plug	approx. m	1,5
Length, exhaust air hose	approx. m	1,5
Product measurements	L x B x H approx. mm	462 x 362 x 778
Measurements, single carton	L x B x H approx. mm	680 x 400 x 855
Weight, single carton	approx. kg	45
Amount per parcel	pcs.	1
Amount per pallet	pcs.	6
Amount per container 40' HQ	pcs.	300

* Performance may be affected by air humidity, roof inclination, and large glass facades/windows.

